

Occhio

Sento head beidseitig Sento head double-sided

Montage- / Bedienungsanleitung

Mounting instructions / user manual

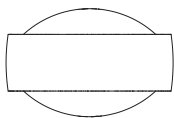

Inhalt / Contents

Sicherheitshinweise	04	Safety precautions	05
Produktbeschreibung	06	Product description	07
Schritt 1		Step 1	
head ohne »air«	09	head without »air«	09
OFF	11	OFF	11
DIM	15	DIM	15
STEP	19	STEP	19
head mit »air«	23	head with »air«	23
OFF + »air«	25	OFF + »air«	25
DIM + »air«	29	DIM + »air«	29
STEP ohne »air«	33	STEP without »air«	33
Schritt 2		Step 2	
Montage	39	Mounting	39
inserts	40	inserts	40
head + body /	48	head + body	48
head abnehmen /	50	remove head	50
Wechsel Karbongriff / Fixierring	52	Changing carbon rod / fixing ring	52
Anhang	55	Appendix	55
Pflegehinweise	56	Care instructions	56
Info & Kontakt	57	Information & contact	57
Technische Daten	58	Technical data	59

Sicherheitshinweise

Lesen Sie die Montage-/Gebrauchsanweisung sorgfältig durch, bevor Sie die Leuchte installieren. Beachten Sie die Sicherheitshinweise in dieser Anleitung genau und bewahren Sie die Anleitung auf.



Dieses Zeichen macht Sie auf eine gefährliche Situation aufmerksam, die eine schwere Verletzung oder den Tod nach sich ziehen kann, wenn sie nicht beachtet wird. Es macht Sie zudem auf mögliche Sachschäden und andere wichtige Informationen in Verbindung mit diesem Produkt aufmerksam.



Die Montage von Elektrokomponenten darf nur von qualifiziertem Fachpersonal durchgeführt werden. Reparaturarbeiten dürfen nur von autorisiertem Fachpersonal oder dem Hersteller durchgeführt werden. Vor allen Arbeiten an der Leuchte (Installation, Reinigung etc.) diese unbedingt vom Stromnetz trennen.



Dieses Zeichen macht Sie auf Situationen aufmerksam, bei denen Sie direkt in das Licht der LED blicken könnten. Dies kann zu Nachbildern und bei längerer Dauer zu Schädigungen der Augen führen.



Sicherheitsabstand zu brennbaren Objekten einhalten: 20 cm!



Dieses Zeichen macht Sie auf heiße Oberflächen aufmerksam, deren Berührung Verbrennungen zur Folge haben können.

Achtung: Die Oberfläche der Leuchte kann nach längerer Betriebsdauer heiß sein! Vor allen Arbeiten an der Leuchte (Montage usw.), Leuchte immer ausschalten und mindestens 30 Minuten abkühlen lassen.

Safety precautions

Read through the mounting/ use instructions carefully before installing the luminaire. Follow the safety precautions in these instructions closely and keep the instructions in a safe place.



This symbol warns you of a dangerous situation which could lead to serious injury or even death if the instructions are not observed. It also draws your attention to possible material damage and provides other important information in connection with this product.



The assembly and installation of electrical components must be carried out only by qualified personnel. Repairs must be carried out only by authorised, qualified personnel or the manufacturer. Before performing any work on the luminaire (installation, cleaning, etc.), it must be disconnected from the mains supply.



This symbol draws your attention to situations in which you could look directly into the light of the LED. This may cause an after-image effect and may result in damage to the eyes if you look at the light directly for prolonged periods.



Maintain the minimum safety distance from flammable materials: 20 cm.



This symbol warns you of hot surfaces, which could cause burns if touched.

Caution: When used for prolonged periods, the surface of the luminaire can become hot. Before performing any work on the luminaire (fitting the luminaire etc.), always switch the luminaire off and let it cool for at least 30 minutes.

Produktbeschreibung

Lichtleistung 18 W oder 26 W
(einstellbar).

Lichtwirkung über optionale inserts
veränderbar, dichroitische Farbfil-
ter zusätzlich einsetzbar. Verstell-
möglichkeit über wärmeentkop-
pelten Karbongriff (head optional
gegen Verdrehen fixierbar).

Extern dimmbar via Phasenab-
schnittdimmer (abhängig vom
Vorschaltgerät) oder über Gesten-
steuerung »touchless control« am
head.

Optional mit Occhio air erhältlich,
Steuerung zusätzlich via Occhio air
App oder Occhio air Controller. Bei
Leuchten mit mehreren heads ist
nur ein »air« head notwendig.

Phasenabschnittdimmer und Occhio air nicht kombinierbar

Product description

Light output, power of light source
18 W or 26 W (adjustable).

Lighting effect changeable by using optional inserts, dichroic color filters can be added. Adjustment via heat-decoupled carbon pin (fixation of head against rotation optional).

Controllable via trailing-edge phasecut dimmer (depending on the power supply unit) or via »touchless control« with gestures at the head.

Optionally available with Occhio air, additional control via Occhio air app or Occhio air controller. For luminaires with multiple heads, only one »air« head is necessary.

trailing-edge phasecut dimmer and Occhio air not combinable



Oberseite / this side up

26 W nicht für den Handbereich empfohlen (Wärmeentwicklung)*
26 W not recommended for the hand area (heat buildup)*

18 W für den Handbereich empfohlen

18 W recommended for the hand area

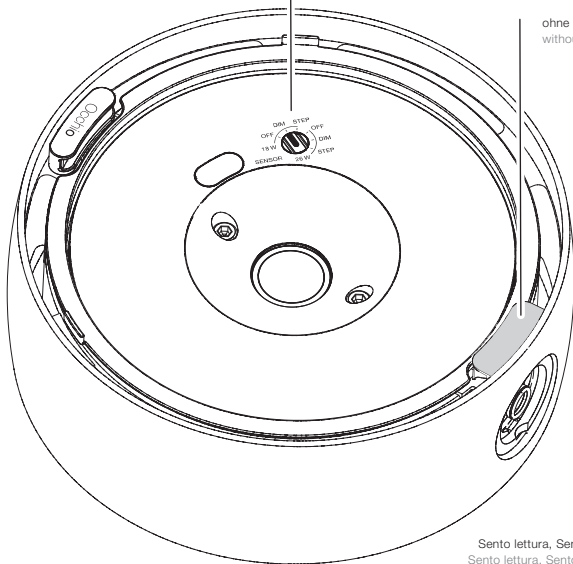

ohne Occhio air
without Occhio air

Sento lettura, Sento tavolo nur mit 18 W*
Sento lettura, Sento tavolo with only 18 W*

head ohne

» air «

Funktionen / Steuerungs-
möglichkeiten

head without

» air «

Functions / control options

OFF

extern schalten und dimmen (Sensor aus)
switch and dim externally (sensor off)

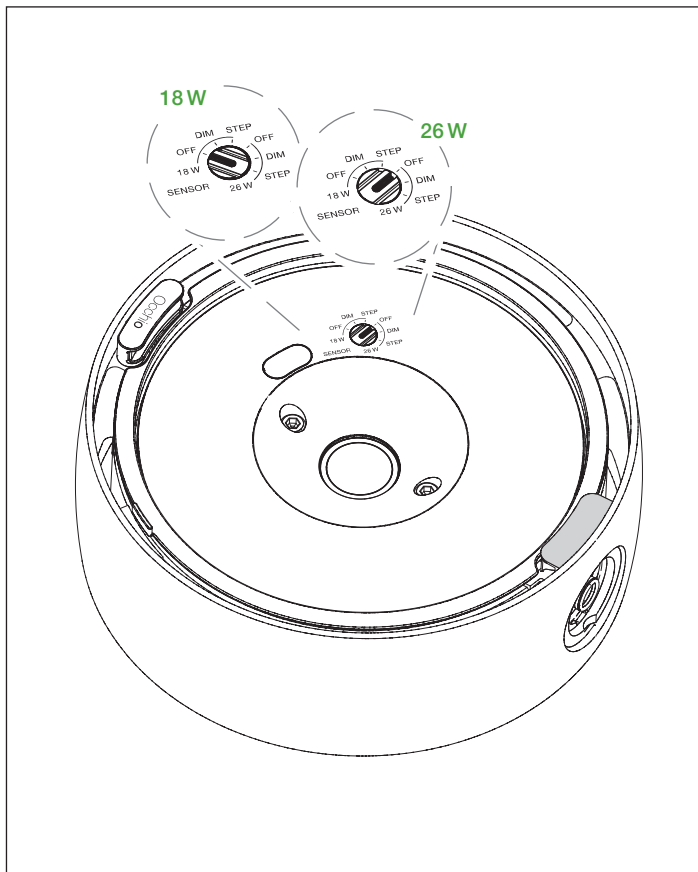

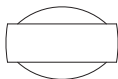

Schalter / Dimmer*
switch / dimmer*



extern Schalten und Dimmen (kein »touchless control«) /
switching and dimming external (no »touchless control«)

* nicht mögl. bei Sento tavolo, Sento terra, Sento lettura; dimmen nur mit Occhio Konverter
(Liste kompatibler Dimmer: www.occhio.com/dim, Phasenabschnittdimmer)
* not possible with Sento tavolo, Sento terra, Sento lettura; dimming only with Occhio converter
(for a list of compatible dimmers, see www.occhio.com/dim_en, trailing-edge phasecut dimmer)

DIM

» touchless control «

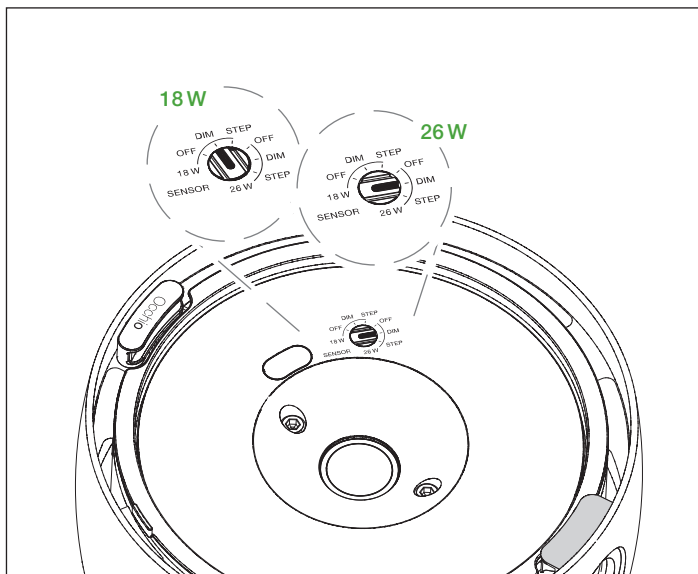

Sensorzone / sensor zone 8 cm

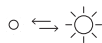
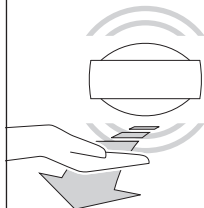

on / off
bewegen / move your hand



dimmen / dim
halten / keep your hand still

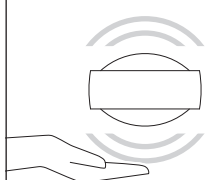

up / down fading
lange halten / keep your hand still for a time
maximale Helligkeit auf eine Seite ziehen /
moves the maximum brightness to one side

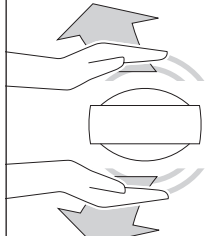

koppeln / entkoppeln
gleichzeitig bewegen / die Leuchte blinkt zur Bestätigung

coupling / decoupling
move hands simultaneously / the luminaire flashes to confirm

optional beide Seiten zusammen oder separat schalten /
optional switch both sides together or separately

STEP

up- / down preset (Sensor aus) / (sensor off)

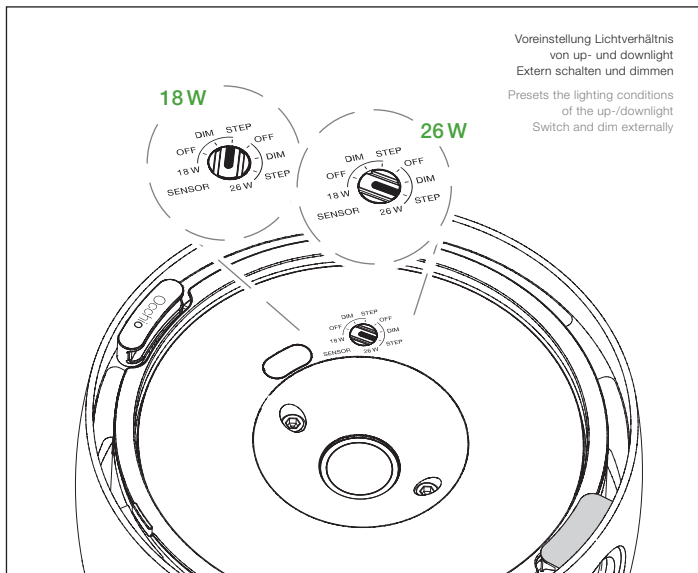

Sensorzone / sensor zone 8 cm

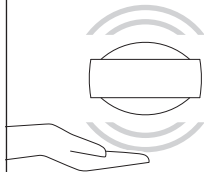

10 Sek. halten / hold for 10 seconds
Leuchte wird entsperrt und blinkt zur Bestätigung /
Luminaire is unlocked and flashes to confirm

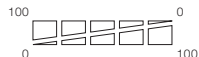
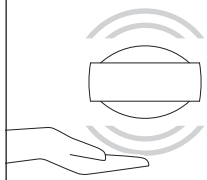

lange halten / keep your hand still for a time
Lichtverhältnis in 5 Stufen einstellen /
Sets the lighting conditions in 5 stages

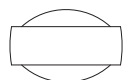

5 Minuten warten oder netzseitig aus-/einschalten /
Wait for 5 minutes or switch on/off at the mains
Einstellung ist nun gespeichert / The setting is now saved



Schalter / Dimmer*
switch / dimmer*



Schalten und Dimmen (kein »touchless control«) /
switching and dimming (no »touchless control«)
Leuchte bleibt in der gespeicherten Einstellung /
The saved setting for the luminaire remains unchanged

* dimmen nur mit Occhio Konverter (Liste kompatibler Dimmer: www.occhio.com/dim, Phasenabschrittdimmer)
* dimming only with Occhio converter (for a list of compatible dimmers, see www.occhio.com/dim_en, trailing-edge phasecut dimmer)



Oberseite / this side up

26 W nicht für den Handbereich empfohlen (Wärmeentwicklung)*
26 W not recommended for the hand area (heat buildup)*

18 W für den Handbereich empfohlen
18 W recommended for the hand area

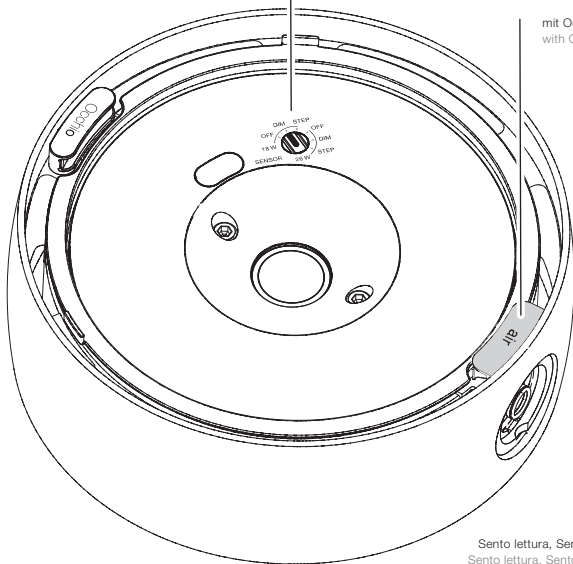

mit Occhio air
with Occhio air

Sento lettura, Sento tavolo nur mit 18W*
Sento lettura, Sento tavolo with only 18W*

head mit

» air «

Funktionen / Steuerungs-
möglichkeiten

head with

» air «

Functions / control options

OFF + » air «

»air« (Sensor aus) / (sensor off)

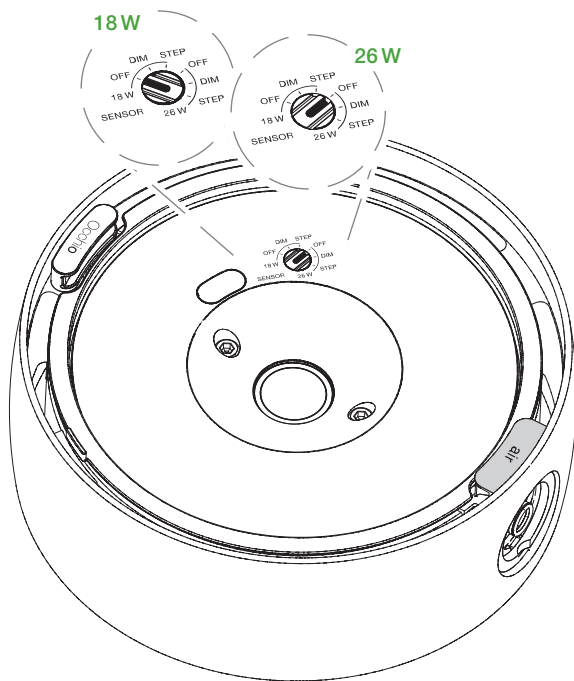

* Phasenabschrittdimmer und Occhio air nicht kombinierbar /
trailing-edge phasecut dimmer and Occhio air not combinable

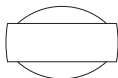

Occhio air siehe separates Handbuch.
Occhio air see seperate manual.

* dimmen nur mit Occhio Konverter (Liste kompatibler Dimmer: www.occhio.com/dim, Phasenabschnittdimmer)

* dimming only with Occhio converter (for a list of compatible dimmers, see www.occhio.com/dim_en, trailing-edge phasecut dimmer)

DIM + » air «

» touchless control « + » air «

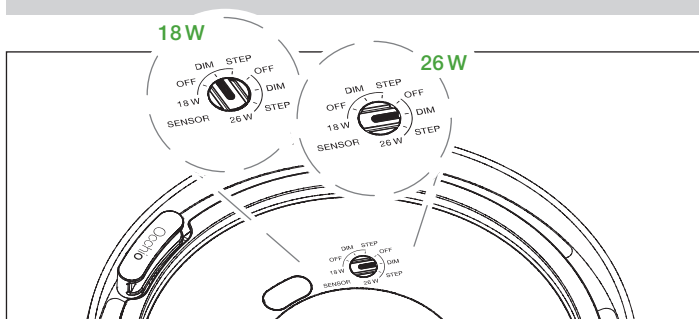

Sensorzone / sensor zone 8 cm

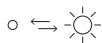
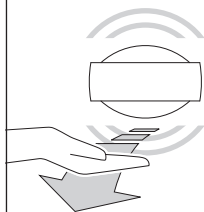

on / off

bewegen / move your hand

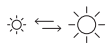
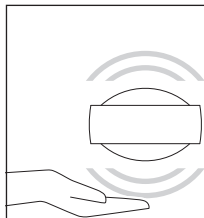

dimmen / dim

halten / keep your hand still

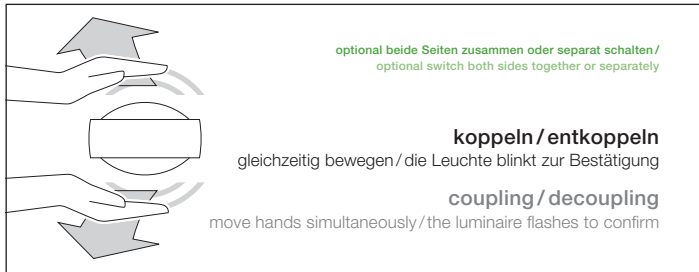
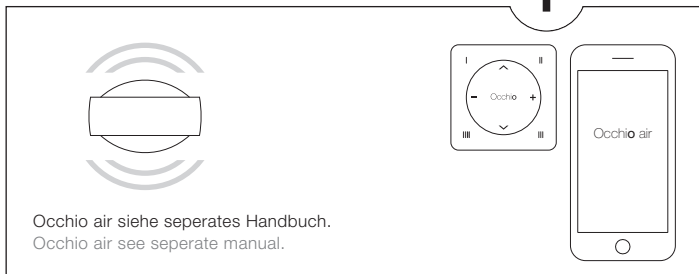
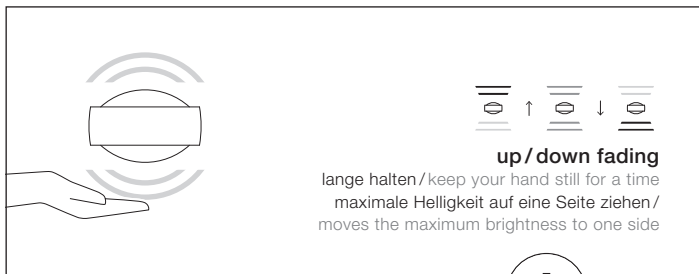

STEP ohne
» air «

STEP without
» air «

up- / down preset (Sensor aus) / (sensor off)

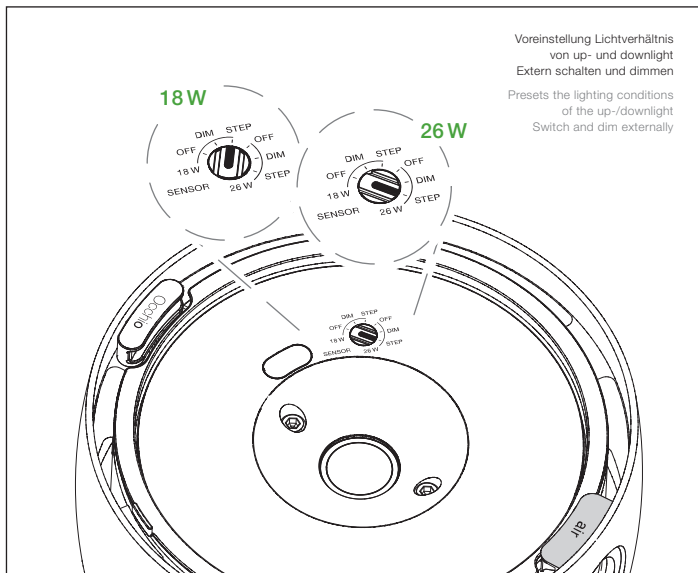

Sensorzone / sensor zone 8 cm

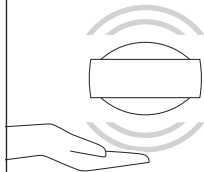

10 Sek. halten / hold for 10 seconds
Leuchte wird entsperrt und blinkt zur Bestätigung /
Luminaire is unlocked and flashes to confirm

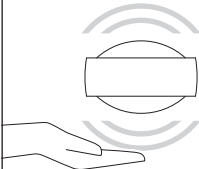

lange halten / keep your hand still for a time
Lichtverhältnis in 5 Stufen einstellen /
Sets the lighting conditions in 5 stages

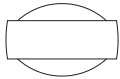

5 Minuten warten oder netzseitig aus-/einschalten /
Wait for 5 minutes or switch on/off at the mains
Einstellung ist nun gespeichert / The setting is now saved



Schalter / Dimmer*
switch / dimmer*



Schalten und Dimmen / switching and dimming
Leuchte bleibt in der gespeicherten Einstellung /
The saved setting for the luminaire remains unchanged
* dimmen nur mit Occhio Konverter / dimming only with Occhio converter

Steuerung via Occhio air controller (optional)

Control via Occhio air controller (optional)

Occhio air controller

Intuitiv bedienbare Fernbedienung mit vier programmierbaren Tasten (Einrichtung via Occhio air App). Unabhängig von der App können einzelne Leuchten, Gruppen und Szenen gesteuert werden. Optional mit Wandhalterung erhältlich.

Maximaler Bedienkomfort und umfassende Steuerung via Bluetooth 4.0 (Bluetooth Low Energy). Schalten, dimmen, faden, color tune, elektrische Höhenverstellung von einzelnen Leuchten, Gruppen und Szenen.

Occhio air controller

Intuitive remote control with four programmable buttons (setup via Occhio air app). Individual luminaires, groups and scenes can be controlled regardless of the app. Available with optional wall mount.

Maximum ease of use and total control via Bluetooth 4.0 (Bluetooth low energy). Switching, dimming, fading, color tune, electric height adjustment of individual luminaires, groups and scenes.



Zum Einrichten des Occhio air controllers wird die Occhio air App benötigt. Eine Video-Kurzanleitung kann unter: www.occhio.com/air-tutorials aufgerufen werden.

To set up the Occhio air controller, the Occhio air app is required. A video quick start guide can be called up at www.occhio.com/air-tutorials.

schalten/switch

⏏ - ⏏⏏⏏ schalten einzelner Leuchten, Gruppen oder Szenen

⏏ - ⏏⏏⏏ switch individual luminaires, groups or scenes

fading*

⤴ ⤵ fading einzelner Leuchten, Gruppen oder Szenen (up/down Lichtverhältnis einstellen)

⤴ ⤵ fading of individual luminaires, groups or scenes (set up/down light ratio)

dimmen/dim

⊕ ⊖ dimmen einzelner Leuchten, Gruppen oder Szenen

⊕ ⊖ dim individual luminaires, groups or scenes

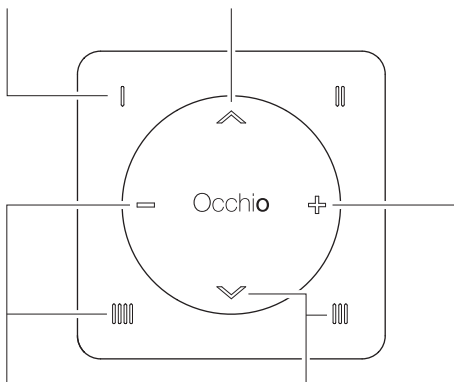

color tune**

⏏ - ⏏⏏⏏ und ⊕ ⊖ Farbtemperatur einzelner Leuchten, Gruppen oder Szenen einstellen

⏏ - ⏏⏏⏏ and ⊕ ⊖ adjust color temperature of individual luminaires, groups or scenes

magic move***

⏏ - ⏏⏏⏏ und ⤴ ⤵ elektrische Höhenverstellung einzelner Leuchten, Gruppen oder Szenen

⏏ - ⏏⏏⏏ and ⤴ ⤵ electronic height adjustment of individual luminaires, groups or scenes

Montage Mounting

Montage inserts / Mounting inserts

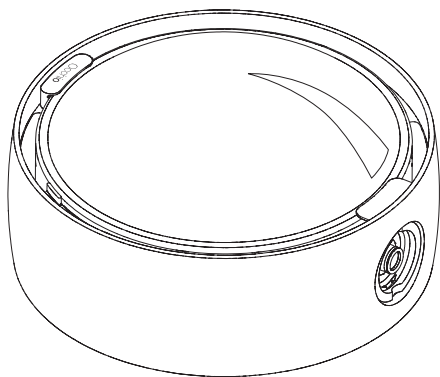

* Nur bei Einstellung 18 W
Only with setting 18 W



Diffusorglas / diffusor glass

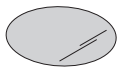

Farbfilter* (optional) /
color filter* (optional)

head

Farbfilter* (optional) /
color filter* (optional)



Diffusorglas / diffusor glass



Version A



Linse / lens



soft edge Glas, satiniertes Glas
oder Farbfilter* (optional) /
soft edge glass, satinised glass
or color filter* (optional)



soft edge Glas, satiniertes Glas
oder Farbfilter* (optional) /
soft edge glass, satinised glass
or color filter* (optional)



Linse / lens



Version D



Diffusorglas / diffusor glass

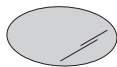

Farbfilter* (optional) /
color filter* (optional)

soft edge Glas, satiniertes Glas
oder Farbfilter* (optional)
soft edge glass, satinised glass
or color filter* (optional)



Linse / lens



Version E



Montage inserts / Mounting inserts



Achtung!
Leuchte vor allen
Arbeiten min 30 Min.
abkühlen lassen.



Caution
Allow the luminaire
to cool down for at
least 30 min. before
all work.

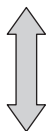

Zum Öffnen drücken.
Push to open.

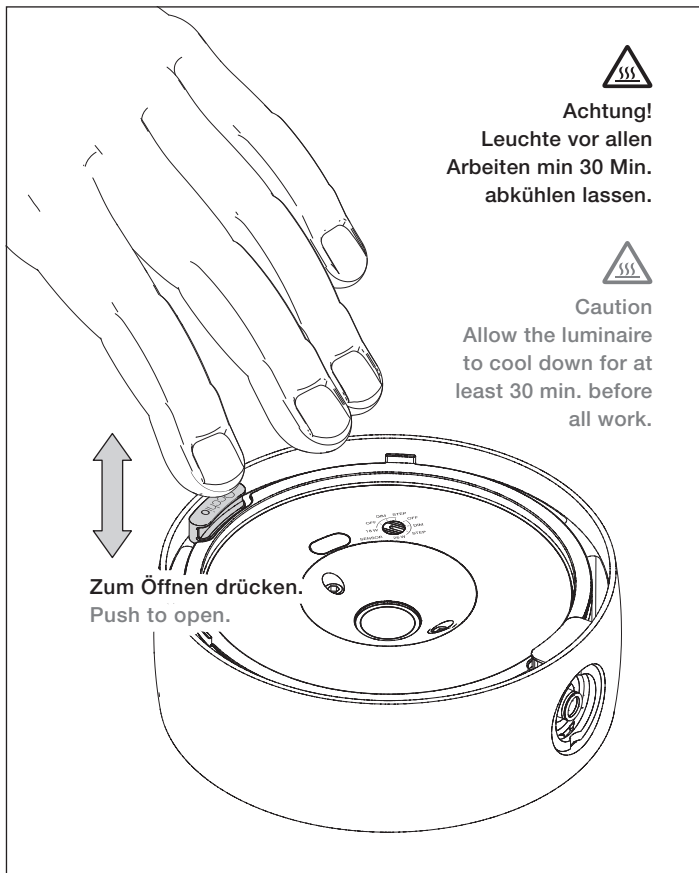



Mehrere inserts gemeinsam einsetzen und auf Hinweise achten!

Use several inserts together and pay attention to notes!

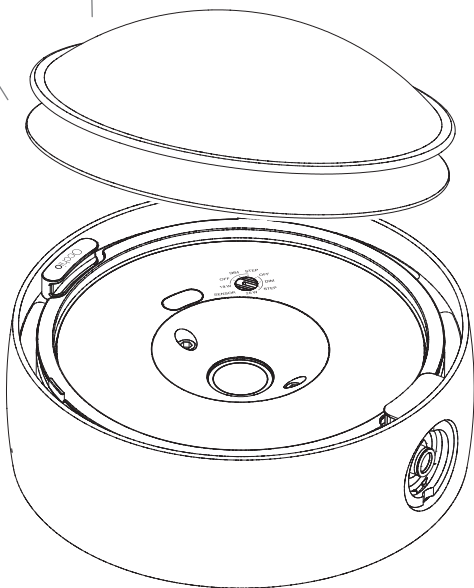

Montage inserts / Mounting inserts

Diffusorglas / diffusor glass



▲ inside

▼ LED

Farbfilter / color filter

Linse / lens

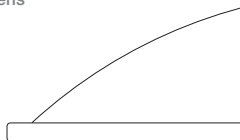

inside ▲

LED ▼

soft edge Glas / soft edge glass

Linse / lens

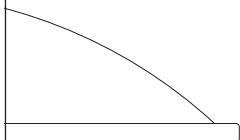

▲ inside

▼ LED

Farbfilter / color filter

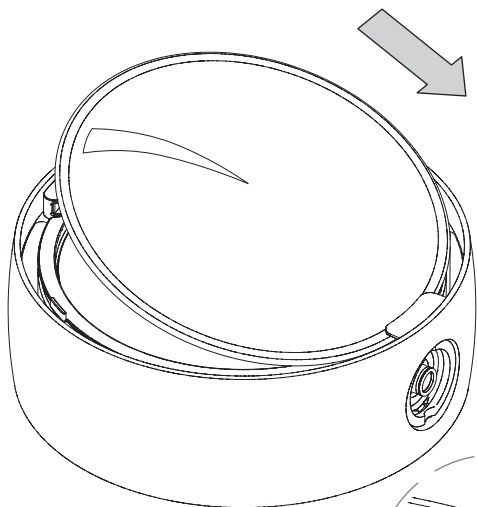

**Feder mit den inserts
leicht eindrücken ...**

**Press the spring with
the inserts slightly in ...**

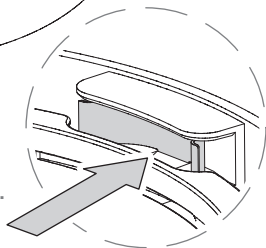

Montage inserts / Mounting inserts

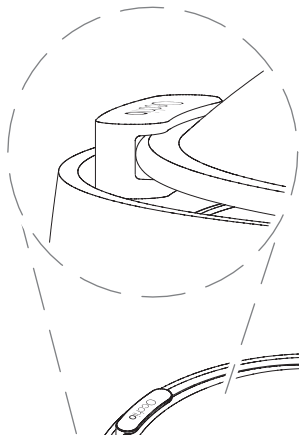

**... und wie abge-
bildet einrasten.**

**... and snap into
place as shown.**

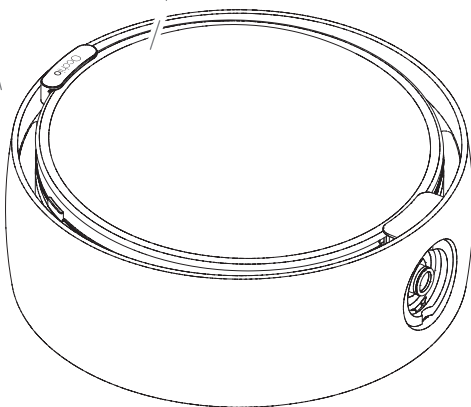



**Die inserts sind nun
fertig montiert.**

**The inserts are com-
pletely mounted.**

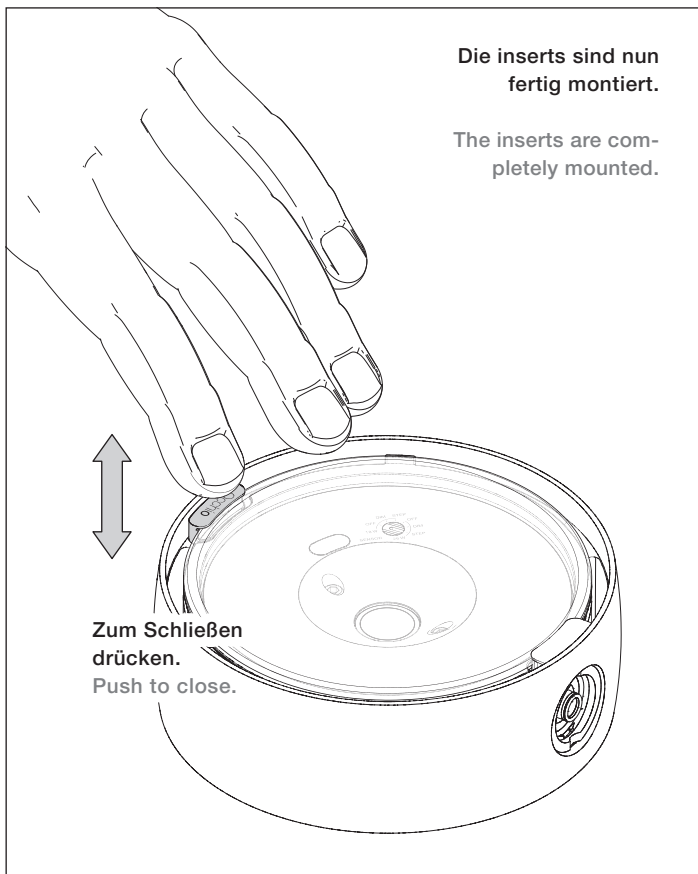

**Zum Schließen
drücken.
Push to close.**

Montage head + body / Mounting head + body



Oberseite /
this side up



head aufstecken und auf die
Ausrichtung achten.

Attach the head and pay
attention to the alignment.

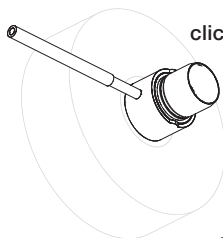

click

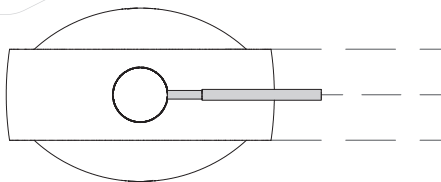
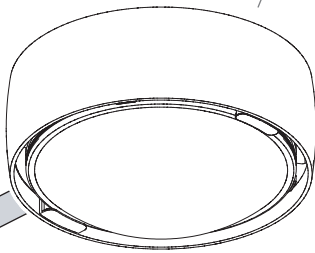
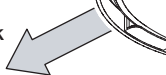



heads müssen gleichen
Typs sein!

heads must be of the
same type!

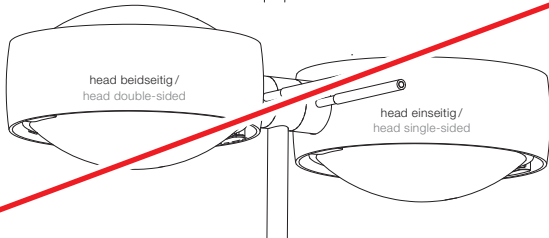
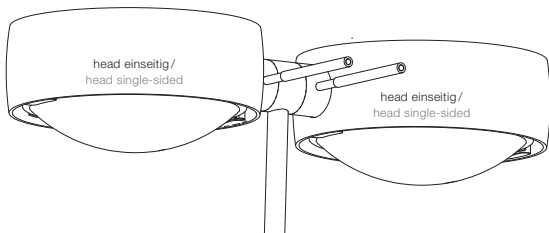
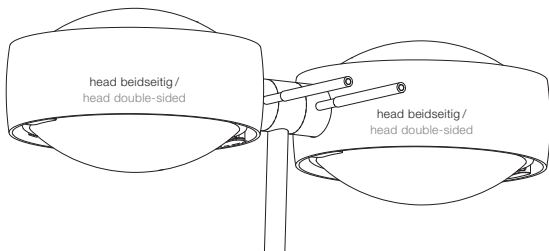

Montage head abnehmen / Mounting remove head

**Karbondröhrchen festhalten, head
drehen bis er sich löst.**

Hold the carbon rod, turn
the head until it releases.

click

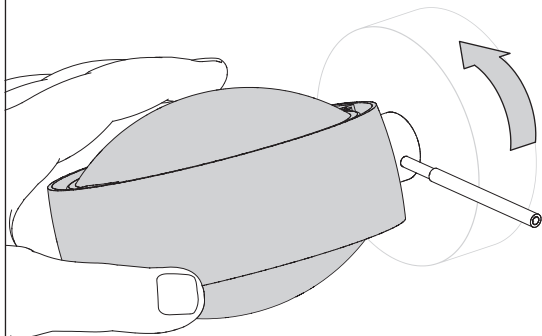



head abnehmen.
remove head.

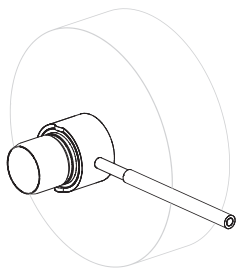
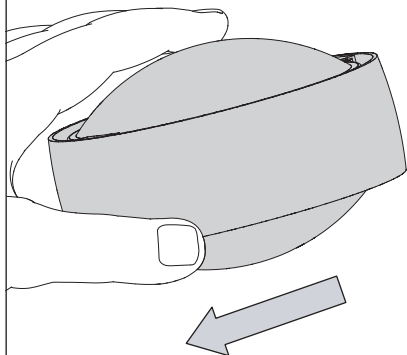

Wechsel Karbongriff /Fixierring Changing carbon rod /fixing ring

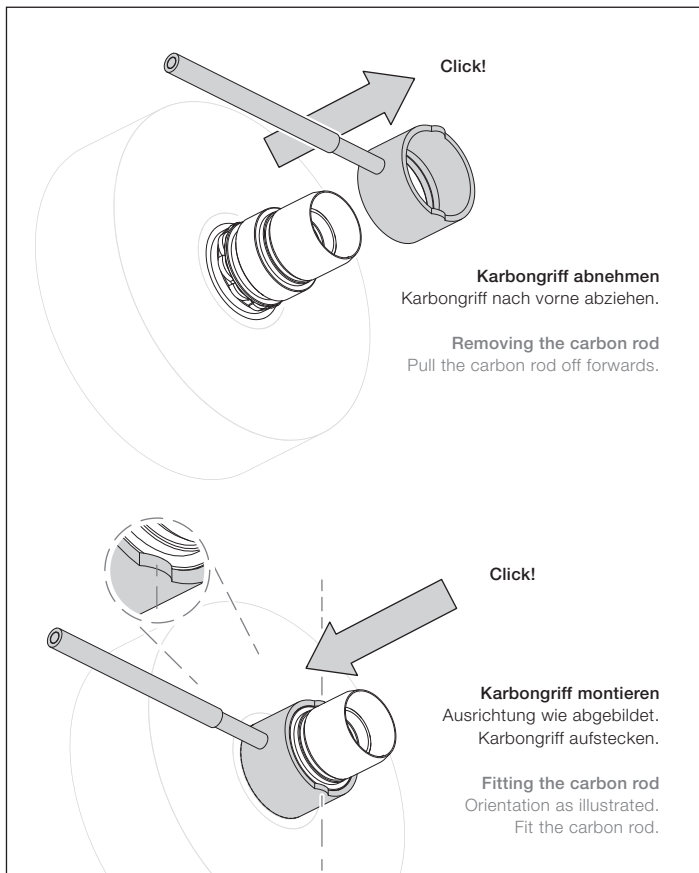

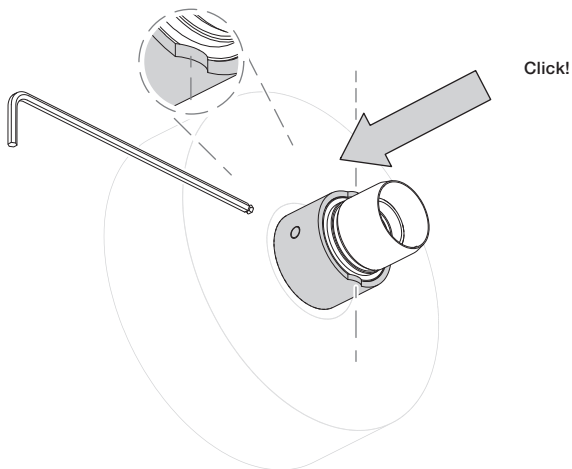
**Fixierring (optional)**

Ausrichtung wie abgebildet. Vor Montage Madenschraube lösen.

Fixierring aufstecken und ggf. mit Sechskantschlüssel gegen Verdrehen sichern.

Fixing ring (optional)

Orientation as illustrated. Before mounting, undo the grub screw.

Fit the fixing ring and, if necessary, secure it against turning using a hexagon key.

Anhang

Appendix

Pflegehinweise

Care instructions

Leuchte nur in abgekühltem Zustand reinigen! Zur Reinigung der Leuchte ein trockenes Mikrofasertuch verwenden. Detaillierte Pflegehinweise sind unter www.occhio.com/de/company/faq zu finden.

Always allow the luminaire to cool down before cleaning! To clean the luminaire, use a dry microfibre cloth. Detailed care instructions are available at www.occhio.com/en/company/faq.

Info & Kontakt

Information & contact

Weitere Fragen beantwortet gerne
Ihr Occhio Fachhändler

Your Occhio specialist retailer will
gladly answer any other questions

www.occhio.com
info@occhio.com

Technische Daten

Technische Daten

Artikelbezeichnung	Sento head beidseitig
Abmessungen	ø 123 mm, H 42 mm (ohne Linse)
Schutzklasse	3
Betriebsspannung	48 V DC, min. 22 W bei 18 W Einstellung, min. 30 W bei 26 W Einstellung
Vorschaltgerät	extern
Dimmung	via head / geeignetem Vorschaltgerät
Material	Aluminium, Stahl verchromt, lackiert oder eloxiert, Kunststoff, Glas, optischer Kunststoff
LED-Leistung	max. 26 W
Zulässige Betriebsbedingung	max. 30°C nur im Innenbereich betreiben
Prüfzeichen	IP 20 CE   

Technische Daten Leuchtmittel

Leuchtmittel	Occhio LED
Ausführung	LED-Chip (wechselbar)
Lebensdauer	> 50.000 Std.

Entsorgung

Bei örtlicher Entsorgungsstelle entsorgen. Der Sento head beidseitig ist recyclebar; RoHS-konform. **Nicht in den Hausmüll geben!**

Technical data

Technical data

Product designation	Sento head double-sided
Dimensions	ø 123 mm, H 42 mm (without lens)
Safety class	3
Supply voltage	48 V DC, min. 22 W for 18 W setting, min. 30 W for 26 W setting
Power supply unit	external
Dimming	via the head / suitable power supply unit
Materials	Aluminium, chrome-plated, painted or anodised steel, plastic, glass, optical plastic
LED power	max. 26 W
Permitted operating conditions	max. 30°C, for indoor use only
Test symbols	IP 20 CE     

Technical data light source

Light source	Occhio LED
Version	LED chip (replaceable)
Life time	> 50.000 Std.

Disposal

Dispose of at a local disposal site. Sento head double-sided is recyclable and RoHS compliant. **Do not dispose of with the household waste!**

Occhio

www.occhio.com



010405944518990610